

ashirvad

by **aliaxis**

PE Manhole

Ashirvad manholes are made of 100% virgin UV stabilised polyethylene (PE) material and are intended for use in underground drainage and sewerage systems.

Ashirvad manholes have been installed in extremely challenging site conditions such as high ground water level!. Ashirvad chambers are suitable for both on-road and off-road installations.

Benefits:

USP's of Ashirvad Manholes

- Ashirvad Manholes are manufactured as per BS EN 13598-2 standards
- Innovative designed ribs to provide extra strength to the product and at the same time act as an uplift prevention system against ground water
- Anti Rodent - Acts as a barrier against Rats. Prevents rat bites which in turn avoids product damage.
- Double layer - For extra strength and durability
- Flexibility - Ashirvad Manholes height can be easily adjusted on site with the help of different risers
- Specially designed FRP steps - For lighter weight and better strength
- Consistent Quality - Ashirvad Manholes are machine manufactured as per leading Indian and International standards. Each and every manhole is of the same precise quality and does not vary.
- Better Visibility - Light blue color inner layer for better visibility during maintenance activities.
- Inherently sealed - Sealing of the pipe to the chamber is achieved with sockets on the chamber base containing rubber seals.

Manholes are an essential part of any sewerage pipeline and are typically required whenever there is a change in direction, diameter or significant change in gradient of the sewerage pipeline. Manholes are required in domestic, commercial and municipal sewerage networks.

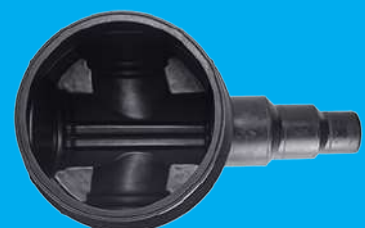

Installation Procedure Overview

Important: Consult Ashirvad for installations where water level is high. All instructions from the Engineer and local regulations must be respected. Following is an overview of installation procedure please consult Ashirvad for detailed instructions.

Rock sand or non cohesive selected material of size less than 16mm without any sharp objects/rocks should be used as back filling material

Fast, easy and safe installation in 5 simple steps:

A - Excavate

- 1 - Excavate 60cm wider and 15cm deeper than the chamber.
- 2 - A base layer of 15cm should be filled and compacted to 95%.
- 3 - Place the chamber on the compacted layer of 15cm.
- 4 - Check the levelling to ensure chamber is horizontally aligned.

B - Connect Inlet

- 1 - To connect inlet pipe(s) drill hole of appropriate diameter with Ashirvad cup saw on pre-marked inlet positions, insert Ashirvad EN 681-1 inlet rubber seal, push the pipe into the seal for a watertight connection. Soap water may be used as lubricant. There is no need for any glue, silicon.
- 2 - Ashirvad seals provide watertight connection and allow for 5° movement in all directions.
- 3 - If due to site constraint you cannot connect the inlet at the pre-marked location then you may connect the inlet anywhere on the body of the chamber however direction of the inlet/outlet in belching should be taken into consideration for proper flow.

C - Connect Outlet

- 1 - Connect the outlet pipe by slipping the socket of the pipe onto the outlet spigot of the chamber. If required smaller unnecessary spigot may be cut off at right angle with a saw.
- 2 - If outlet pipe is PVC then use PRJ socket for watertight connection. Do not use glue or silicone.

D - Backfill and Compact

- 1 - Check levelling of chamber and ensure horizontal alignment
- 2 - Back filling material should be inserted under the manhole in order to fill-in the gap between the manhole and the compacted layer. Use hand tamped.
- 3 - Back fill around the manhole in layers of 30cm and compact to 95% with a mechanical vibrating stamper (50 Kg).
- 4 - Continue to fill-in and compact in layers up to ground/cover level.

E - Adjust Height and Install Cover

- 1 - The height of the chamber can be adjusted on site by cutting the upper edge of the chamber.
- 2 - Ashirvad PE covers can be used for installation in the garden or non-traffic areas.
- 3 - For installation in traffic areas, a concrete load bearing ring around the neck of the chamber should be used. On this ring appropriate class C/D cover with frame should be installed. Ashirvad can provide more details on load bearing ring and installation. Site Engineer should be consulted.





by **aliaxis**

Manholes specifications and ranges

Sl No	Size of Manhole	Height	Inlet	Outlet
1	5 way Manhole 500 diameter	500MM	110/160	110/160
2		750MM		
3		1000MM		
4	5 way Manhole 600 diameter	500MM	110/160	110/160
5		750MM		
6		1000MM		
7		1250MM		
8	5 way Manhole 800 diameter	1000MM	110/160	110/160
9		1250MM		
10		1500MM		
11	5 way Manhole 1000 diameter single piece	1250MM	110/160/200	110/160/200
12	5 way Manhole 1000 diameter	Top	110/160/200	110/160/200
13		Riser (middle)		
14		Bottom		
15	3 way Manhole 600 diameter	500MM	160/200/250	160/200/250
16		750MM		
17		1000MM		
18		1250MM		

ashirvad

by **alixis**

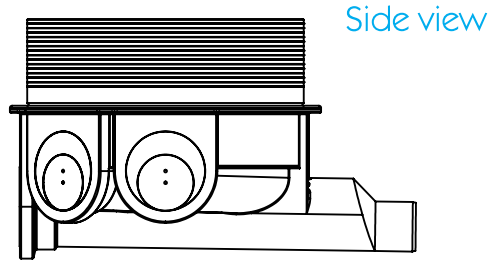
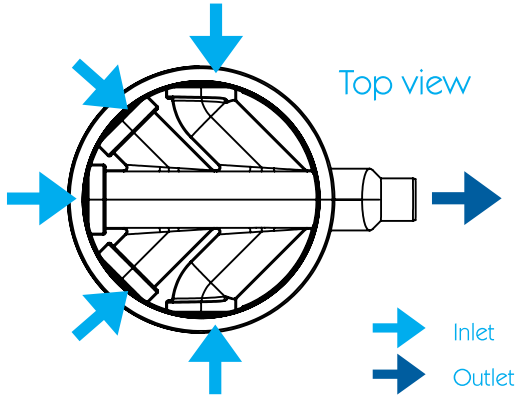

Uplift Prevention

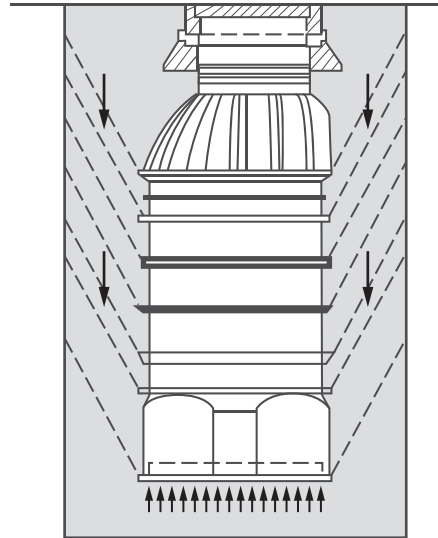

The strategically designed ribs on Ashirvad chambers interlock with the soil to prevent uplift. Engineering calculations that DN 1000 Ashirvad chambers have a safety factor well over 1.8 against buoyancy caused by existing groundwater.



Ashirvad Pipes Pvt. Ltd.

4-B, Attibele Industrial Area, Hosur Road, Bengaluru - 562 107, India.

Ph: +91 80 2806 1000 / 2806 1700 F: +91 80 2806 1080

E: info@ashirvad.com | www.ashirvad.com